

Slouching Towards Utopia

- An Economic History of the Long 20th Century, 1870-2010
- by J. Bradford DeLong
- <https://bit.ly/3pP3Krk>
- Forthcoming September 6 from Basic/Hachette

The Economic Pie



Aristotle & Ancient Greek Robots

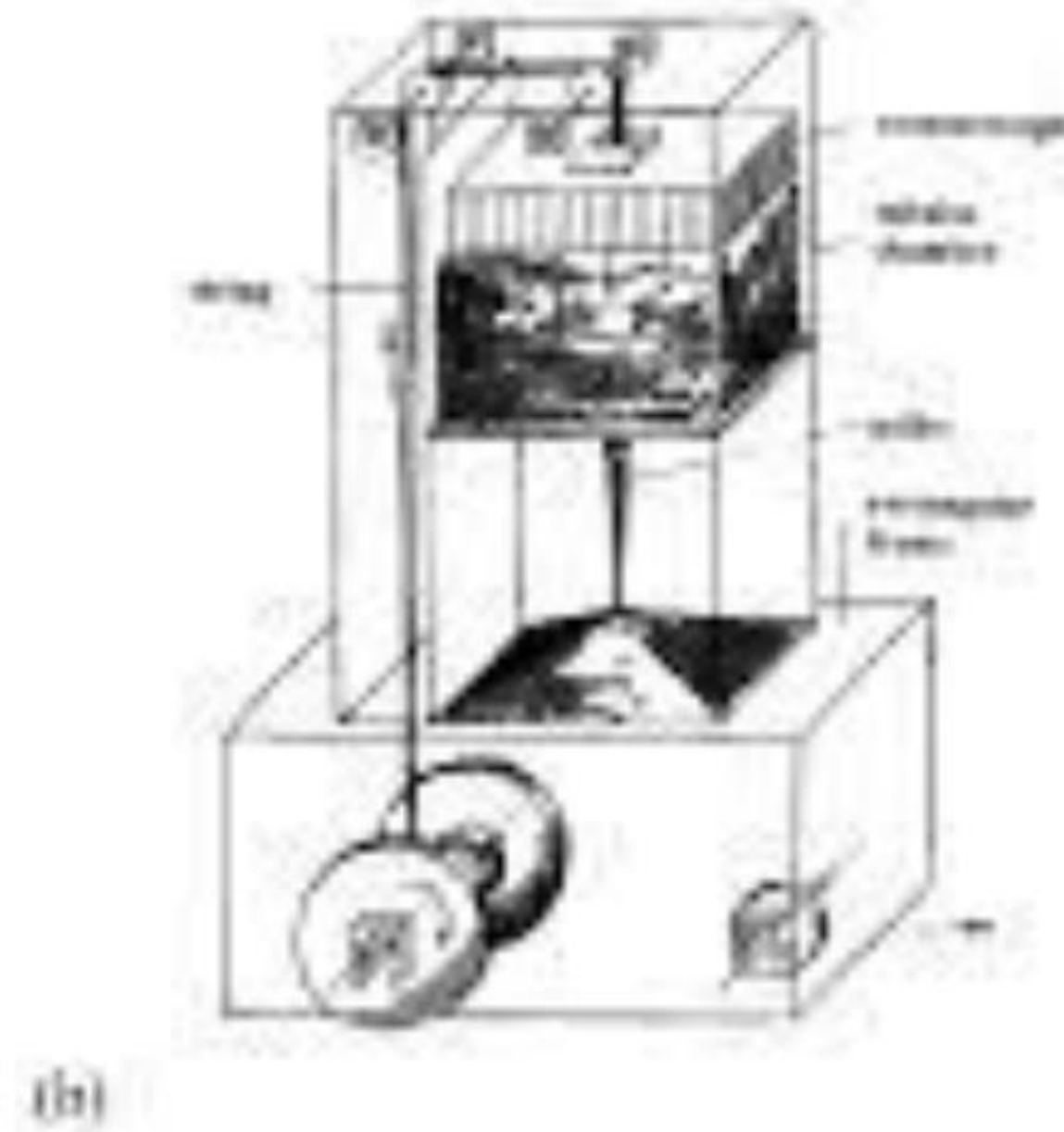
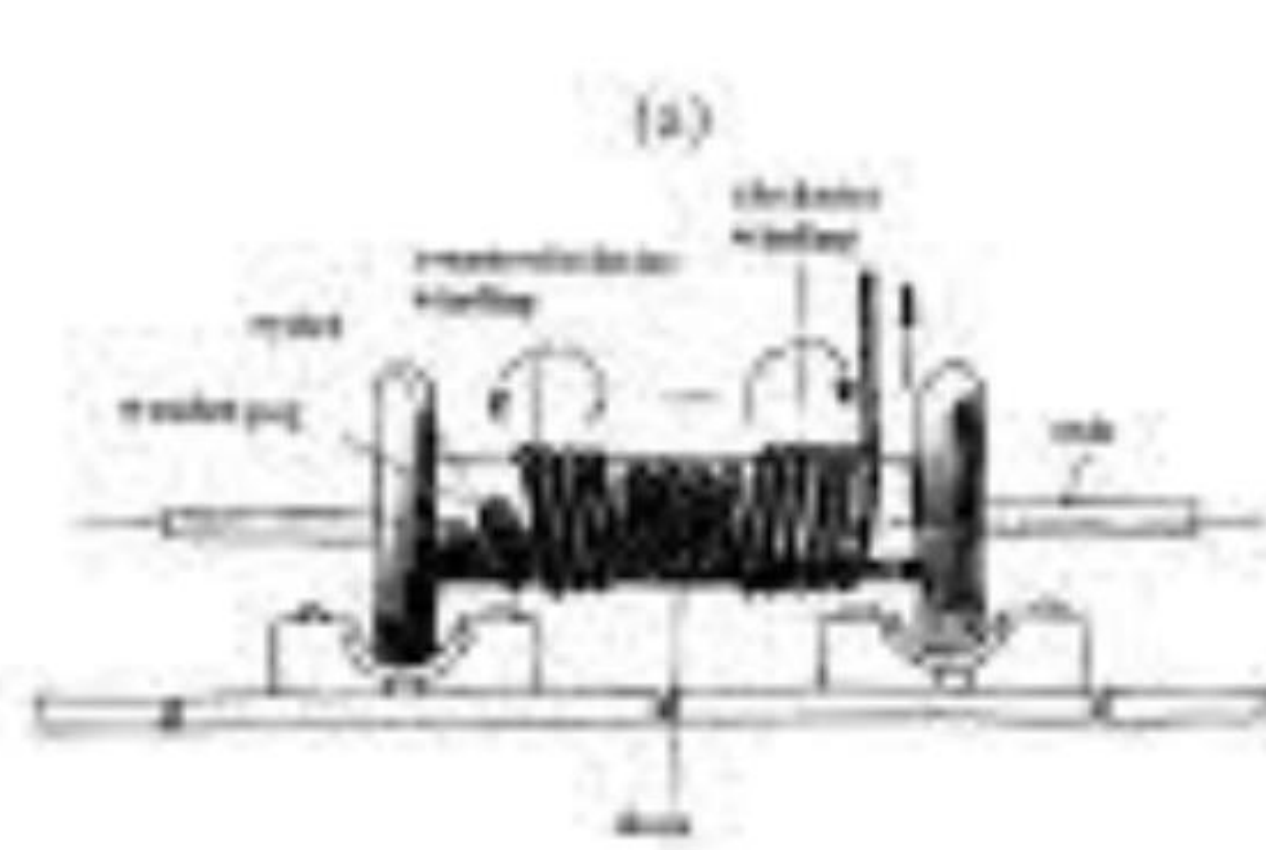

“Technology”

Date	Technological Ideas-Stock Growth Rate h	Technological Ideas Stock Level H (1870 = 1)	Average Annual Real Income per Capita y	Total Human Population P (millions)	Total Real World Income Y (billions)
-48000	0.002%	0.011	\$1,200	0.2	\$0.24
-8000	0.003%	0.036	\$1,200	2	\$2.4
-6000	0.009%	0.043	\$900	5	\$4.5
-3000	0.018%	0.074	\$900	15	\$14
-1000	0.030%	0.136	\$900	50	\$45
150	0.060%	0.272	\$900	200	\$180
800	0.014%	0.297	\$900	240	\$216
1500	0.052%	0.429	\$900	500	\$450
1770	0.149%	0.643	\$1,100	750	\$825
1870	0.442%	1.000	\$1,300	1300	\$1,690
2010	2.159%	20.557	\$11,600	6900	\$80,040

- Technology:
 - $H = y\sqrt{P}$
 - $H_{1870} = 1$
- Why the $\sqrt{\quad}$?
- What alternatives?



Persistent Steampunk Counterfactual World?



John Stuart Mill

Hitherto it is questionable if all the mechanical inventions yet made have lightened the day's toil of any human being. They have enabled a greater population to live the same life of drudgery and imprisonment, and an increased number of manufacturers and others to make fortunes... [and] increased the comforts of the middle classes...

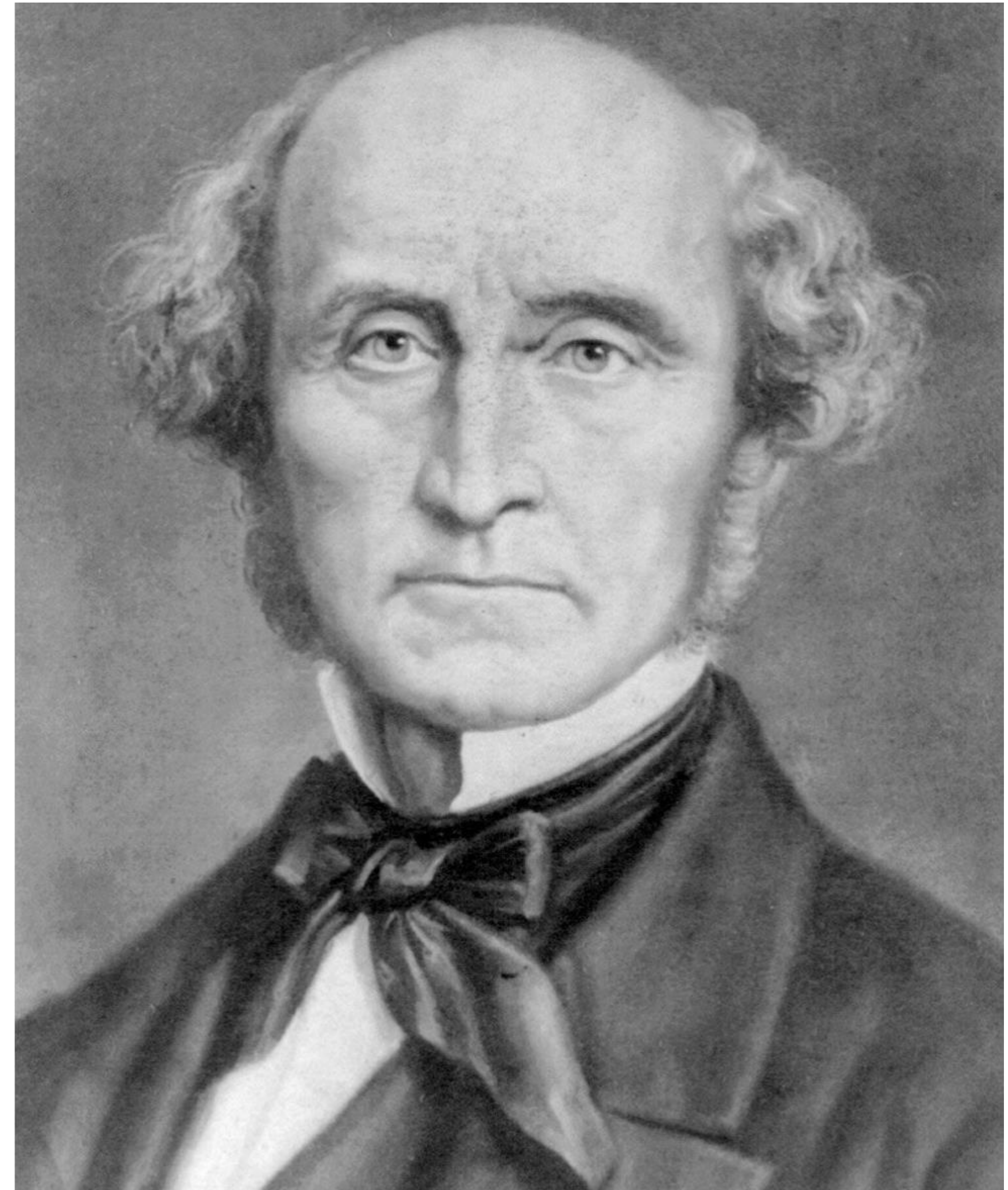

“Technology”

Date	Technological Ideas-Stock Growth Rate h	Technological Ideas Stock Level H (1870 = 1)	Average Annual Real Income per Capita y	Total Human Population P (millions)	Total Real World Income Y (billions)
-48000	0.002%	0.011	\$1,200	0.2	\$0.24
-8000	0.003%	0.036	\$1,200	2	\$2.4
-6000	0.009%	0.043	\$900	5	\$4.5
-3000	0.018%	0.074	\$900	15	\$14
-1000	0.030%	0.136	\$900	50	\$45
150	0.060%	0.272	\$900	200	\$180
800	0.014%	0.297	\$900	240	\$216
1500	0.052%	0.429	\$900	500	\$450
1770	0.149%	0.643	\$1,100	750	\$825
1870	0.442%	1.000	\$1,300	1300	\$1,690
2010	2.159%	20.557	\$11,600	6900	\$80,040

- Technology:
 - $H = y\sqrt{P}$
 - $H_{1870} = 1$
- Why the $\sqrt{\quad}$?
- What alternatives?



Friedrich A. von Hayek

The market
giveth; the
market taketh
away: blessed
be the name of
the market...



Schumpeterian Creative Destruction, Again & Again...



Guessing at Income Levels

- Is every single one of us richer than Nathan Meyer Rothschild?



?

Where utopia?
Where Lambo?
When Moon?

Schumpeterian Creative Destruction, Again & Again...



Karl Polanyi

The market
was made for
man, not man
for the
market...



John Maynard Keynes

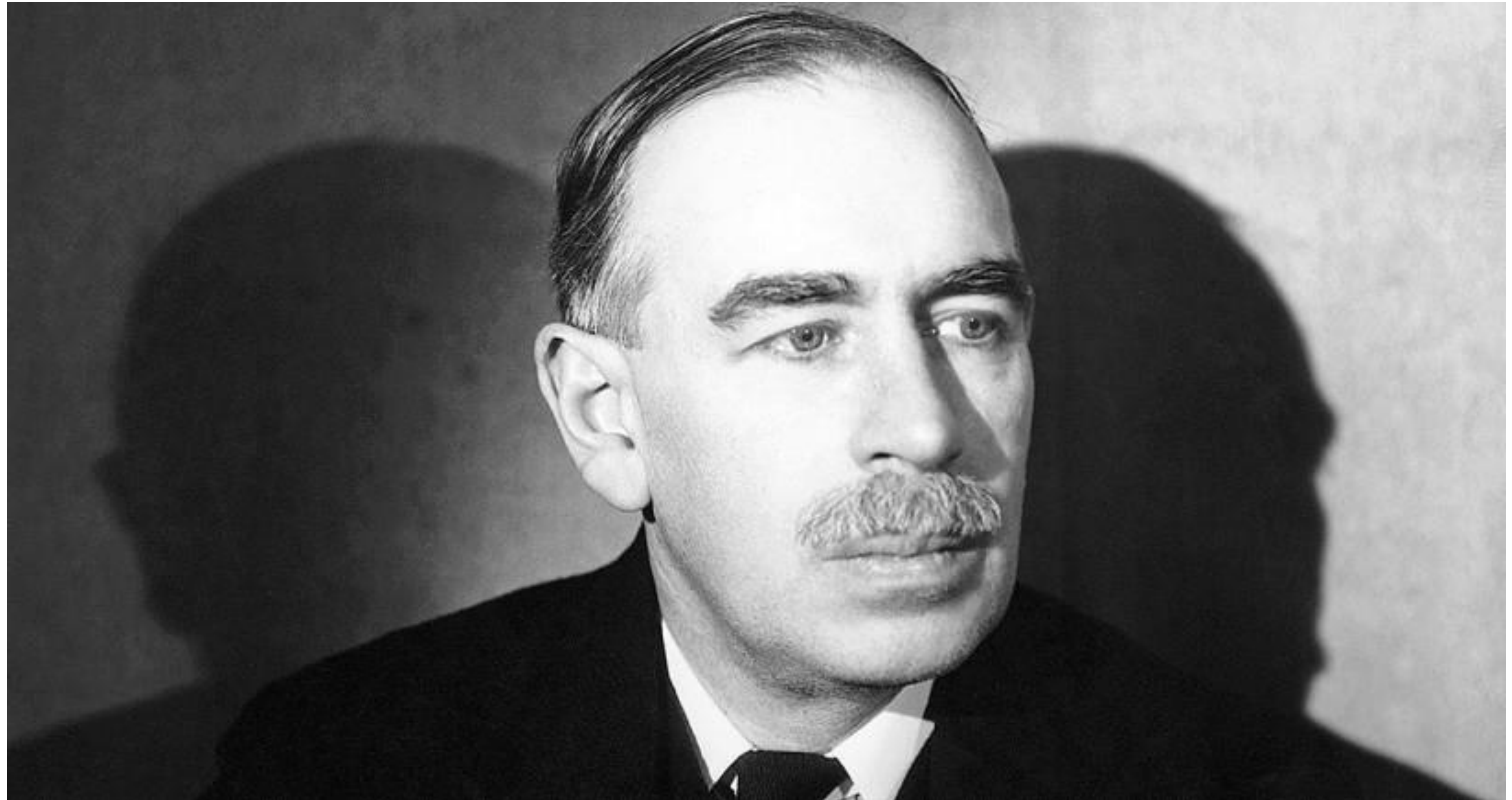

Social Democracy & Neoliberalism

A rough periodization of the long 20th century:

- “Economic El Dorado”, 1870-1914
- WWI & Failed Reconstruction, 1914-1929
- The Great Depression & WWII, 1929-1945
- 30 Glorious Years, 1945-1975
- The Age of Neoliberalism, 1975-2010
- ???, 2010-?

Ethno-Nationalist Fear & Rage?

Neoliberalism Promised Many Things:

- But, in the Global North, at least, it did not deliver on any of them...
- Save for its promise to make the rich richer...
- So why is it so stubbornly persistent?

John Maynard Keynes, Again

[That] assumes... a plan exists.... [But] we lack more than usual a coherent scheme of progress, a tangible ideal. All the political parties alike have their origins in past ideas and not in new ideas.... No one has a gospel. The next move is with the head...

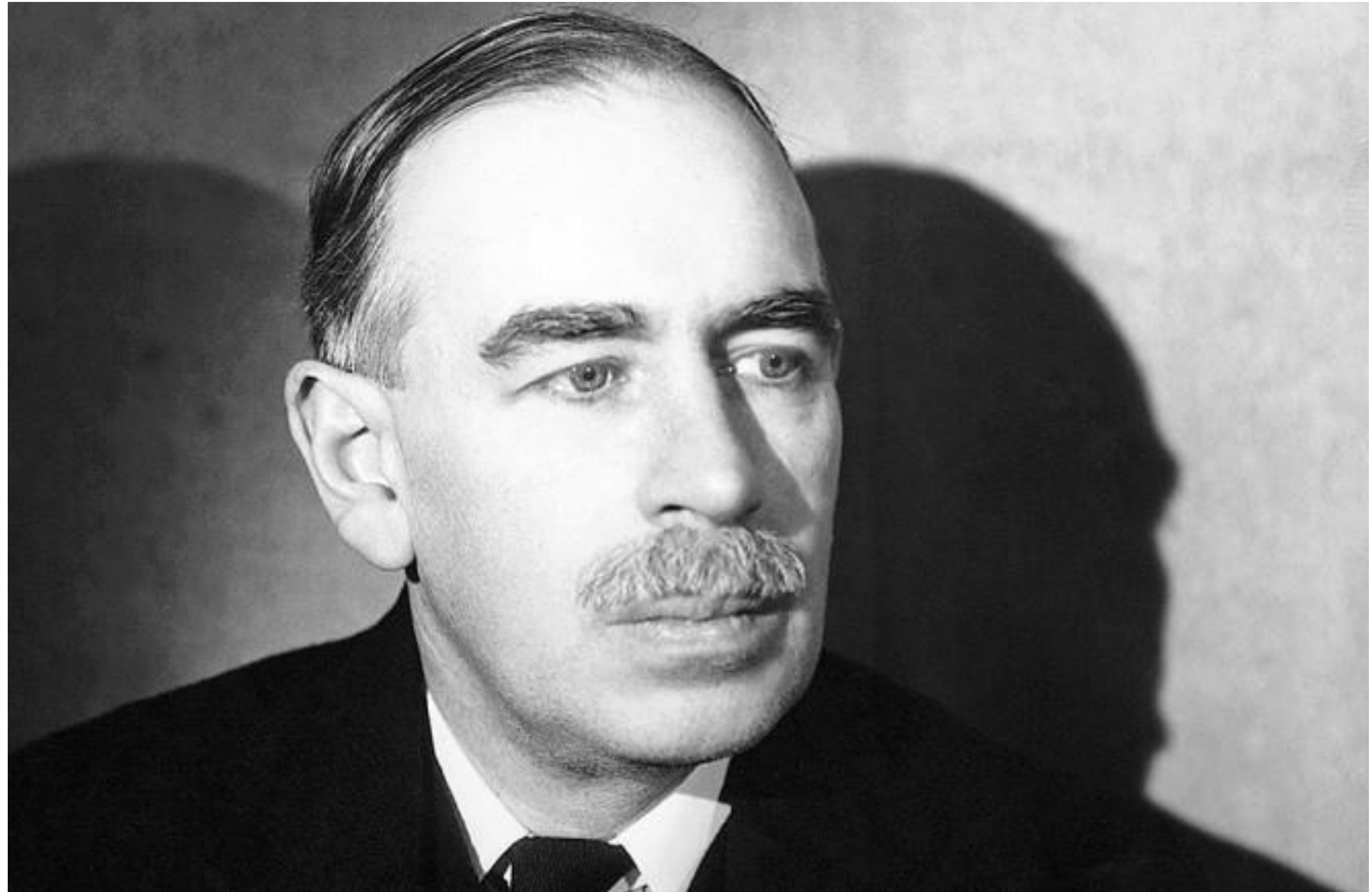

Other Books I Might Have Written...

- The Michael Polanyi book.
- The David Landes book.
- The Joseph Schumpeter book.
- The John Maynard Keynes book
- The reacting-to-“Red-Vienna” books:
 - The Karl Polany book.
 - The Friedrich von Hayek book.
 - The Peter Drucker book.
 - The Karl Popper book.

Kindleberger : Minsky :: DeLong : Polanyi

- Minsky was a genius
- Minsky wrote *terribly*
- Polanyi was a genius
- Polanyi writes...
- Kindleberger showed how you could use Minsky's frameworks of analysis to understand stuff...

What Is Wrong with This Book?

- In what ways is its pseudo-neo-Polanyiesque Grand Narrative insufficient?